



MAGNUM PLUS

Бескомпромиссная производительность

Системы охлаждения для контейнеров

MAGNUM PLUS

- *Эффективность*
- *Низкий уровень воздействия на окружающую среду*
- *Надежность*
- *Производительность*



Бескомпромиссная производительность

Как основатель отрасли охлаждения на транспортных средствах компания Thermo King всегда стремилась создавать новаторские изделия и технологии и позволять клиентам по всему миру достигать новых уровней эффективности и производительности.

Модель MAGNUM PLUS™ - результат многолетних практических испытаний, проведенных с ее предшественником, агрегатом MAGNUM™. к компания Thermo King представила на рынке модель MAGNUM PLUS™, созданную с помощью современных технологий, исследований и разработок. Это новая веха в отрасли в части эффективности, производительности, удобстве эксплуатации и надежности. Модель MAGNUM PLUS™ задумана как ответ на самые жесткие требования.



Specifications

System Net Cooling Capacity - Full Cool MAGNUM+ Model - Air Cooled Condensing*			
Return air to evaporator coil inlet	460/230V, 3 Phase, 60 Hz Power		
	Net Cooling Capacity		Power Consump
	60 Hz Capacity B/hr	60 Hz Capacity kW	60 Hz Power kW
21.1 °C (70 F)	56,700	16.603	11.550
1.7 °C (35 F)	40,945	11.990	11.030
-17.8 °C (0 F)	24,785	7.258	7.570
-29 °C (-20 F)	17,215	5.041	6.600
-35 °C (-31 F)	14,000	4.104	6.030

*System net cooling capacity with a 38 °C (100 F) ambient air temperature and R-404 A.

Dimensions	
Height	2,235 mm (88 inches)
Width	2,026 mm (79.8 inches)
Depth	420 mm (16.5 inches)
Weight	397 Kg (875 lb)

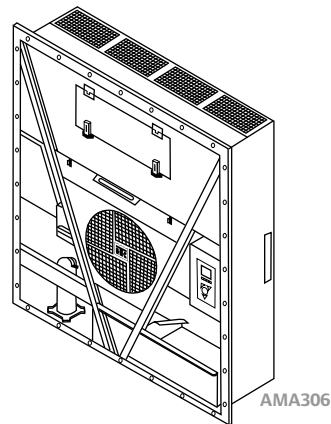

AMA306

Evaporator Airflow Specifications		System Net Heating Capacity*				
MAGNUM+	460/230V, 3 Phase, 60 Hz Power			380/190V, 3 Phase, 50 Hz Power		
	Heating Capacity			Heating Capacity		
	Watts	Kcal/hr	BTU/hr	Watts	Kcal/hr	BTU/hr
	5,250	4,515	17914	3,900	3,353	13,300

*System net heating capacity includes electric resistance rods and fan heat.

Insist on Genuine Thermo King Replacement Parts

Engineered to provide optimal performance and maximum life, Thermo King genuine service parts protect your investment and provide you peace of mind and confidence no matter where your equipment operates. Genuine Thermo King replacement parts are proven time after time to beat the competition in side-by-side testing. Never settle for less.

WARRANTY SUMMARY

Thermo King Warranty are available on request from your local Thermo King Dealer. Please refer to document TK50048 for the Thermo King Container unit warranty.

Ingersoll Rand Climate Control Technologies provides equipment and services for:

TRANSPORT REFRIGERATION



Sea Cargo



Air Cargo



Road Cargo

HEATING, VENTILATION & AIR CONDITIONING



Bus



Rail

STATIONARY REFRIGERATION



Commercial Applications



Industrial Applications



Providing equipment and services to manage controlled-temperature environments for food and other perishables, our Climate Control Technologies sector encompasses both transport and stationary refrigeration solutions. Our product brands include Thermo King®, a world leader in transport temperature control systems, and Hussmann® - Koxka® manufacturer of refrigeration and food merchandising equipment.

www.thermoking.com www.hussmann.com www.koxka.com www.ingersollrand.com

For further information please contact: